



MODEL W1831
SHOP FOX®
OSCILLATING SPINDLE SANDER



OWNER'S MANUAL
(FOR MODELS MANUFACTURED SINCE 3/12)

Phone: (360) 734-3482 • Online Technical Support: tech-support@shopfox.biz



COPYRIGHT © MARCH, 2012 BY WOODSTOCK INTERNATIONAL. REVISED APRIL, 2013 (TR)

WARNING: NO PORTION OF THIS MANUAL MAY BE REPRODUCED IN ANY SHAPE OR FORM WITHOUT

THE WRITTEN APPROVAL OF WOODSTOCK INTERNATIONAL, INC.

#ST14859 Printed in China



WARNING!

This manual provides critical safety instructions on the proper setup, operation, maintenance, and service of this machine/tool. Save this document, refer to it often, and use it to instruct other operators.

Failure to read, understand and follow the instructions in this manual may result in fire or serious personal injury—including amputation, electrocution, or death.

The owner of this machine/tool is solely responsible for its safe use. This responsibility includes but is not limited to proper installation in a safe environment, personnel training and usage authorization, proper inspection and maintenance, manual availability and comprehension, application of safety devices, cutting/sanding/grinding tool integrity, and the usage of personal protective equipment.

The manufacturer will not be held liable for injury or property damage from negligence, improper training, machine modifications or misuse.



WARNING!

Some dust created by power sanding, sawing, grinding, drilling, and other construction activities contains chemicals known to the State of California to cause cancer, birth defects or other reproductive harm. Some examples of these chemicals are:

- Lead from lead-based paints.
- Crystalline silica from bricks, cement and other masonry products.
- Arsenic and chromium from chemically-treated lumber.

Your risk from these exposures varies, depending on how often you do this type of work. To reduce your exposure to these chemicals: Work in a well ventilated area, and work with approved safety equipment, such as those dust masks that are specially designed to filter out microscopic particles.

Contents

INTRODUCTION	2	ACCESSORIES	18
Woodstock Technical Support	2	Sander Accessories	18
SAFETY	6	MAINTENANCE	19
Standard Machinery Safety Instructions	6	Schedule	19
Additional Safety for Sanders	8	Cleaning	19
ELECTRICAL	9	SERVICE	20
Circuit Requirements	9	General	20
Polarized Plug.....	10	Changing Motor Brushes.....	20
Extension Cords	10	Troubleshooting.....	22
SETUP	11	Wiring Diagram	23
Unpacking	11	PARTS	24
Inventory	11	Main Breakdown	24
Machine Placement	12	Main Parts List	25
Cleaning Machine.....	12	Label Placement	26
Bench Mounting.....	13	WARRANTY	29
Assembly.....	14		
Dust Collection	14		
Test Run.....	15		
OPERATIONS	16		
General	16		
Disabling Switch	16		
Sanding Drum/Sleeve Installation	17		
Sanding	17		





INTRODUCTION

Woodstock Technical Support

This machine has been specially designed to provide many years of trouble-free service. Close attention to detail, ruggedly built parts and a rigid quality control program assure safe and reliable operation.

Woodstock International, Inc. is committed to customer satisfaction. Our intent with this manual is to include the basic information for safety, setup, operation, maintenance, and service of this product.

We stand behind our machines! In the event that questions arise about your machine, please contact Woodstock International Technical Support at (360) 734-3482 or send e-mail to: tech-support@shopfox.biz. Our knowledgeable staff will help you troubleshoot problems and process warranty claims.

If you need the latest edition of this manual, you can download it from <http://www.shopfox.biz>.

If you have comments about this manual, please contact us at:

Woodstock International, Inc.
Attn: Technical Documentation Manager
P.O. Box 2309
Bellingham, WA 98227
Email: manuals@woodstockint.com



MACHINE SPECIFICATIONS



© Woodstock International, Inc. • Phone: (800) 840-8420 • Web: www.shopfox.biz

MODEL W1831 SHOP FOX® OSCILLATING SPINDLE SANDER

Product Dimensions

Weight..... Not Available lbs.
 Width (side-to-side) x Depth (front-to-back) x Height..... 15-9/16 x 14-1/8 x 17 in.
 Footprint (Length x Width)..... 15-1/2 x 14 in.

Shipping Dimensions

Type..... Cardboard Box
 Content..... Machine
 Weight..... 34 lbs.
 Length x Width x Height..... 19 x 16 x 21 in.
 Must Ship Upright..... N/A

Electrical

Power Requirement..... 120V, Single-Phase, 60 Hz
 Prewired Voltage..... 120V
 Full-Load Current Rating..... 3.5A
 Minimum Circuit Size..... 15A
 Connection Type..... Cord & Plug
 Power Cord Included..... Yes
 Power Cord Length..... 6 ft.
 Power Cord Gauge..... 18 AWG
 Plug Included..... Yes
 Included Plug Type..... 1-15
 Switch Type..... Paddle Safety Switch w/Removable Key

Motors

Main

Type..... Permanent Magnet Motor
 Horsepower..... 1/2 HP
 Phase..... Single-Phase
 Amps..... 3.5A
 Power Transfer V-Belt Drive
 Bearings..... Sealed & Permanently Lubricated



Spindle Sander Info

Sanding Drum Diameters.....	1/2, 3/4, 1, 1-1/2, 2, 3 in.
Sanding Drum Length.....	4-1/2 in.
Spindle Speed.....	2000 RPM
Spindle Oscillation.....	58 SPM
Stroke Length.....	5/8 in.
Table Length.....	15 in.
Table Width.....	11-1/2 in.
Table Thickness.....	1-5/16 in.
Table-to-Floor Height.....	13 in.
Spindle Shaft Diameter.....	1/2 in.
Number of Table Inserts.....	6

Construction Materials

Base.....	Plastic
Table.....	Cast Iron

Other Related Info

Number of Dust Ports.....	1
Dust Port Size.....	1-1/2 in.

Features

- Space-saving benchtop style.
- Locking power switch with removable key.
- Sanding drums store neatly in the base for easy, organized access.
- Includes 3 spindle washers: 5/8, 7/8, 1-3/4 in.
- Includes 6 table inserts: 1/2, 3/4, 1, 1-1/2, 2, 3 in.
- Includes 6 sanding sleeves: 1/2, 3/4, 1, 1-1/2, 2, 3 in.
- Includes 5 rubber sanding spindles: 3/4, 1, 1-1/2, 2, 3 in.

Controls and Features

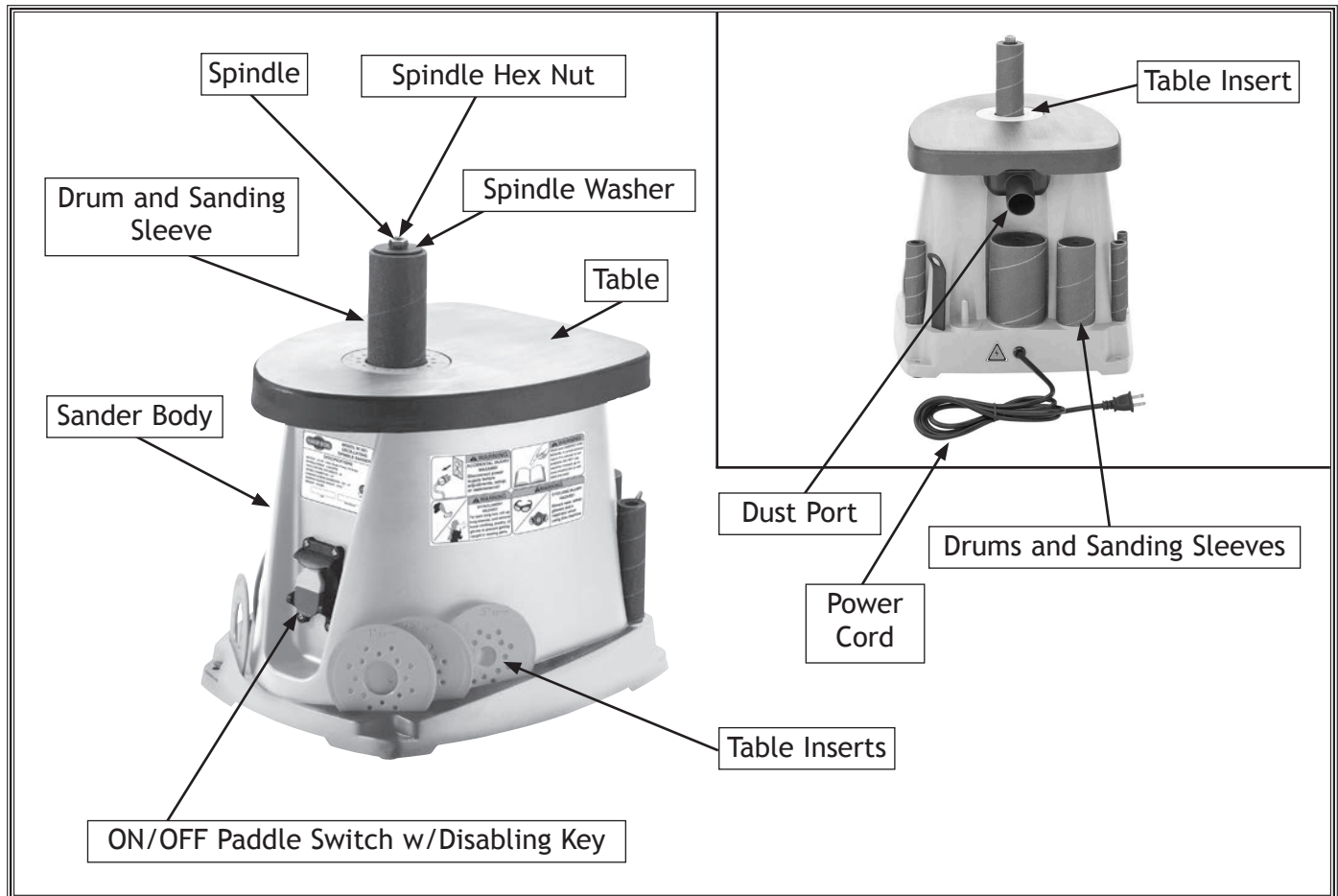

Figure 1. Machine identification.

⚠️ WARNING

For Your Own Safety Read This Manual Before Operating Spindle Sander

- a) Wear eye protection.
- b) Support workpiece on worktable.
- c) Minimize pinch hazards. Use the smallest table insert possible with sanding drum.
- d) Avoid kickback. Feed workpiece against rotation of drum.
- e) Avoid entanglement with spinning drum. Do not wear gloves, necktie, or loose clothing. Tie back long hair.

SAFETY

For Your Own Safety,

The purpose of safety symbols is to attract your attention to possible hazardous conditions. This manual uses a series of symbols and signal words intended to convey the level of importance of the safety messages. The progression of symbols is described below. Remember that safety messages by themselves do not eliminate danger and are not a substitute for proper accident prevention measures—this responsibility is ultimately up to the operator!



Indicates an imminently hazardous situation which, if not avoided, **WILL** result in death or serious injury.



Indicates a potentially hazardous situation which, if not avoided, **COULD** result in death or serious injury.



Indicates a potentially hazardous situation which, if not avoided, **MAY** result in minor or moderate injury.

NOTICE

This symbol is used to alert the user to useful information about proper operation of the equipment or a situation that may cause damage to the machinery.

Standard Machinery Safety Instructions

OWNER'S MANUAL. Read and understand this owner's manual **BEFORE** using machine.

TRAINED OPERATORS ONLY. Untrained operators have a higher risk of being hurt or killed. Only allow trained/supervised people to use this machine. When machine is not being used, disconnect power, remove switch keys, or lock-out machine to prevent unauthorized use—especially around children. Make workshop kid proof!

DANGEROUS ENVIRONMENTS. Do not use machinery in areas that are wet, cluttered, or have poor lighting. Operating machinery in these areas greatly increases the risk of accidents and injury.

MENTAL ALERTNESS REQUIRED. Full mental alertness is required for safe operation of machinery. Never operate under the influence of drugs or alcohol, when tired, or when distracted.

ELECTRICAL EQUIPMENT INJURY RISKS. You can be shocked, burned, or killed by touching live electrical components or improperly grounded machinery. To reduce this risk, only allow an electrician or qualified service personnel to do electrical installation or repair work, and always disconnect power before accessing or exposing electrical equipment.

DISCONNECT POWER FIRST. Always disconnect machine from power supply **BEFORE** making adjustments, changing tooling, or servicing machine. This eliminates the risk of injury from unintended startup or contact with live electrical components.

EYE PROTECTION. Always wear ANSI-approved safety glasses or a face shield when operating or observing machinery to reduce the risk of eye injury or blindness from flying particles. Everyday eyeglasses are not approved safety glasses.

WEARING PROPER APPAREL. Do not wear clothing, apparel, or jewelry that can become entangled in moving parts. Always tie back or cover long hair. Wear non-slip footwear to avoid accidental slips, which could cause loss of workpiece control.

HAZARDOUS DUST. Dust created while using machinery may cause cancer, birth defects, or long-term respiratory damage. Be aware of dust hazards associated with each workpiece material, and always wear a NIOSH-approved respirator to reduce your risk.

HEARING PROTECTION. Always wear hearing protection when operating or observing loud machinery. Extended exposure to this noise without hearing protection can cause permanent hearing loss.

REMOVE ADJUSTING TOOLS. Tools left on machinery can become dangerous projectiles upon startup. Never leave chuck keys, wrenches, or any other tools on machine. Always verify removal before starting!

INTENDED USAGE. Only use machine for its intended purpose and never make modifications not approved by Woodstock. Modifying machine or using it differently than intended may result in malfunction or mechanical failure that can lead to serious personal injury or death!

AWKWARD POSITIONS. Keep proper footing and balance at all times when operating machine. Do not overreach! Avoid awkward hand positions that make workpiece control difficult or increase the risk of accidental injury.

CHILDREN & BYSTANDERS. Keep children and bystanders at a safe distance from the work area. Stop using machine if they become a distraction.

GUARDS & COVERS. Guards and covers reduce accidental contact with moving parts or flying debris—make sure they are properly installed, undamaged, and working correctly.

FORCING MACHINERY. Do not force machine. It will do the job safer and better at the rate for which it was designed.

NEVER STAND ON MACHINE. Serious injury may occur if machine is tipped or if the cutting tool is unintentionally contacted.

STABLE MACHINE. Unexpected movement during operation greatly increases risk of injury or loss of control. Before starting, verify machine is stable and mobile base (if used) is locked.

USE RECOMMENDED ACCESSORIES. Consult this owner's manual or the manufacturer for recommended accessories. Using improper accessories will increase risk of serious injury.

UNATTENDED OPERATION. To reduce the risk of accidental injury, turn machine **OFF** and ensure all moving parts completely stop before walking away. Never leave machine running while unattended.

MAINTAIN WITH CARE. Follow all maintenance instructions and lubrication schedules to keep machine in good working condition. A machine that is improperly maintained could malfunction, leading to serious personal injury or death.

CHECK DAMAGED PARTS. Regularly inspect machine for any condition that may affect safe operation. Immediately repair or replace damaged or mis-adjusted parts before operating machine.

MAINTAIN POWER CORDS. When disconnecting cord-connected machines from power, grab and pull the plug—NOT the cord. Pulling the cord may damage the wires inside, resulting in a short. Do not handle cord/plug with wet hands. Avoid cord damage by keeping it away from heated surfaces, high traffic areas, harsh chemicals, and wet/damp locations.

EXPERIENCING DIFFICULTIES. If at any time you experience difficulties performing the intended operation, stop using the machine! Contact Technical Support at (360) 734-3482.

Additional Safety for Sanders

FEED RATE. Never jam a workpiece against the sanding surface. This can cause the workpiece to kick back or damage the machine. Firmly hold the workpiece and ease it against the spindle using light pressure.

AVOIDING ENTANGLEMENT. Keep loose clothing articles such as sleeves, belts or jewelry items away from the spindle. These items could get entangled in the spindle, resulting in serious personal injury. Never wear gloves when operating the spindle sander.

HAND PLACEMENT. Do not place hands near, or in contact with, sanding surfaces during operation to avoid personal injury.

WORKPIECE HANDLING. Hold the workpiece with both hands to maintain control while sanding (or use an appropriate holding jig) to reduce the likelihood of losing control of the workpiece and having it thrown from the machine.

SANDING SLEEVES. Worn or damaged sanding sleeves can tear apart and become entangled in the spindle or be thrown from the machine, resulting in personal injury or property damage. Replace sanding sleeves as required.

FOREIGN MATERIAL. Always inspect stock for nails, staples, knots, and other imperfections that could be dislodged and thrown from the machine during sanding operations.

DUST COLLECTION. Never operate the sander without an adequate dust collection system in place and running. Proper dust collection reduces dust in the work area, which decreases the risk of long-term respiratory damage.

DIRECTION. Never sand tapered or pointed stock with the point facing the feed direction to avoid the workpiece being thrown from the machine.

POWER DISCONNECT. Disconnect the machine from the power source before changing the sanding sleeve to avoid injuries in the event of an accidental startup.

RESPIRATOR USE. Always use a respirator that is approved for wood dust when using this machine to reduce the risk of short and long term respiratory illness. A dust collector is not an adequate substitute.

TABLE INSERTS. Always use the table insert that fits closest to the diameter of the installed sanding drum. A pinch hazard exists from the gap between the table and the oscillating drum. Keeping this gap as small as possible reduces the risk of this hazard.



⚠️ WARNING
READ and understand this entire manual before using this machine. Serious personal injury may occur if safety and operational information is not understood and followed. **DO NOT** risk your safety by not reading!

⚠️ CAUTION

USE this and other machinery with caution and respect. Always consider safety first, as it applies to your individual working conditions. No list of safety guidelines can be complete—every shop environment is different. Failure to follow guidelines could result in serious personal injury, damage to equipment or poor work results.

ELECTRICAL

Circuit Requirements

This machine must be connected to the correct size and type of power supply circuit, or fire or electrical damage may occur. Read through this section to determine if an adequate power supply circuit is available. If a correct circuit is not available, a qualified electrician **MUST** install one before you can connect the machine to power.

A power supply circuit includes all electrical equipment between the breaker box or fuse panel in the building and the machine. The power supply circuit used for this machine must be sized to safely handle the full-load current drawn from the machine for an extended period of time. (If this machine is connected to a circuit protected by fuses, use a time delay fuse marked D.)

Full-Load Current Rating

The full-load current rating is the amperage a machine draws at 100% of the rated output power. On machines with multiple motors, this is the amperage drawn by the largest motor or sum of all motors and electrical devices that might operate at one time during normal operations.

Full-Load Current Rating at 120V 3.5 Amps

Circuit Requirements for 110V

This machine can be converted to operate on a 110V power supply (details about voltage conversion can be found later in this manual). The 110V power supply circuit must have a verified ground and meet the requirements that follow:

Circuit Type 120V, 60 Hz, Single-Phase
Circuit Size 15 Amps
Plug/Receptacle NEMA 1-15

⚠ WARNING

The machine must be properly set up before it is safe to operate. **DO NOT** connect this machine to the power source until instructed to do later in this manual.

⚠ WARNING



Incorrectly wiring or grounding this machine can cause electrocution, fire, or machine damage. To reduce this risk, only an electrician or qualified service personnel should do any required electrical work on this machine.

NOTICE

The circuit requirements listed in this manual apply to a dedicated circuit—where only one machine will be running at a time. If this machine will be connected to a shared circuit where multiple machines will be running at the same time, consult with an electrician to ensure that the circuit is properly sized for safe operation.

ELECTRICAL

Polarized Plug

To reduce the risk of electric shock, this machine has a polarized plug (one blade is wider than the other). This plug will fit in a polarized outlet only one way. If the plug does not fit fully in the outlet, turn it 180 degrees and try again. If it still does not fit, contact a qualified electrician to install the proper outlet. Do not change the plug in any way.

Extension Cords

We do not recommend using an extension cord with this machine. Extension cords cause voltage drop, which may damage electrical components and shorten motor life. Voltage drop increases with longer extension cords and the gauge smaller gauge sizes (higher gauge numbers indicate smaller sizes).

Any extension cord used with this machine must contain a ground wire, match the required plug and receptacle, and meet the following requirements:

- Minimum Gauge Size at 120V 16 AWG
- Maximum Length (Shorter is Better) 50 ft.

WARNING

The machine must be properly set up before it is safe to operate. **DO NOT** connect this machine to the power source until instructed to do later in this manual.

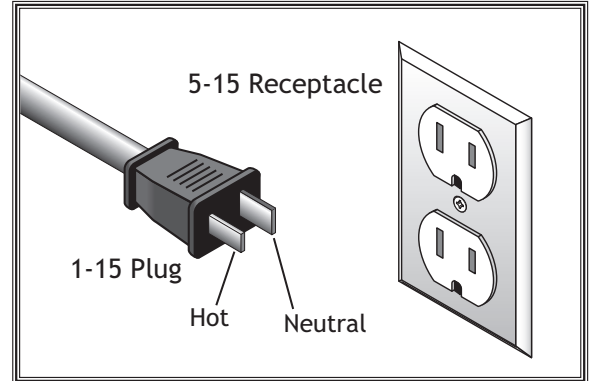

Figure 2. NEMA 1-15 plug & receptacle.

SETUP

Unpacking

This machine has been carefully packaged for safe transportation. If you notice the machine has been damaged during shipping, please contact your authorized Shop Fox dealer immediately.

Inventory

The following is a description of the main components shipped with the Model W1831. Lay the components out to inventory them.

Note: *If you can't find an item on this list, check the mounting location on the machine or examine the packaging materials carefully. Occasionally we pre-install certain components for safer shipping.*

Box Inventory (Figure 3)

Qty

- A. Spindle Sander Assembly1
- B. Table Inserts 1/2", 3/4", 1", 1 1/2", 2", 3" 1 Each
- C. Arbor Wrench.....1
- D. Spindle Hex Nut.....1
- E. Spindle Washers 5/8", 7/8", 1 3/4" 1 Each
- F. Sanding Drums 3/4", 1", 1 1/2", 2", 3" 1 Each
- G. Sanding Sleeves 1/2", 3/4", 1", 1 1/2", 2", 3" 1 Each
- H. Base Washer 2 3/4"1

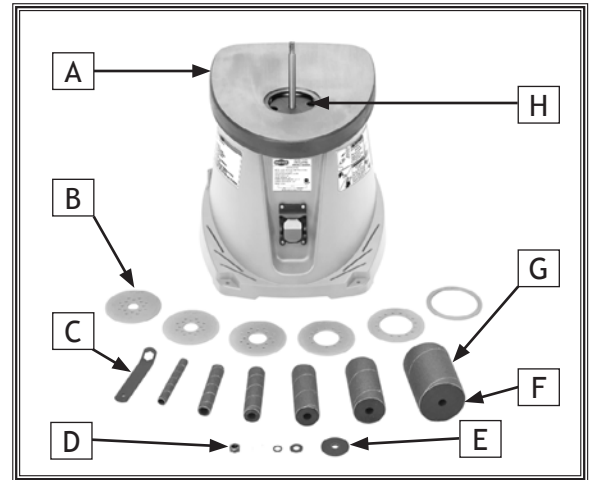
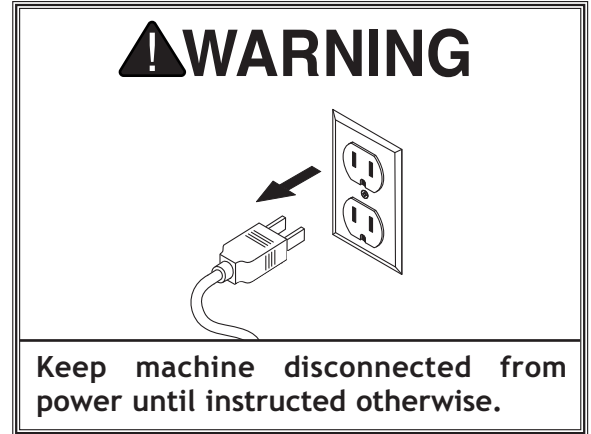

Figure 3. Box contents.

SETUP

Machine Placement

- **Floor Load:** This machine distributes a heavy load in a small footprint. Some residential floors may require additional bracing to support both machine and operator.
- **Working Clearances:** Consider existing and anticipated needs, size of material to be processed through the machine, and space for auxiliary stands, work tables or other machinery when establishing a location for your Machine Type.
- **Lighting:** Lighting should be bright enough to eliminate shadow and prevent eye strain.
- **Electrical:** Electrical circuits must be dedicated or large enough to handle amperage requirements. Outlets must be located near each machine, so power or extension cords are clear of high-traffic areas. Follow local electrical codes for proper installation of new lighting, outlets, or circuits.

Cleaning Machine

The table and other unpainted parts of your machine are coated with a waxy grease that protects them from corrosion during shipment. Clean this grease off with a solvent cleaner or citrus-based degreaser. DO NOT use chlorine-based solvents such as brake parts cleaner or acetone—if you happen to splash some onto a painted surface, you will ruin the finish.

SETUP

	<p>! WARNING NEVER clean with gasoline or other petroleum-based solvents. Most have low flash points, which make them extremely flammable. A risk of explosion and burning exists if these products are used. Serious personal injury may occur if this warning is ignored!</p>
--	--

	<p>! CAUTION INJURY HAZARD! Untrained users can injure themselves with this machine. Restrict access to machine when you are away, especially if it is installed where children are present.</p>
--	---

	<p>! CAUTION ALWAYS work in well-ventilated areas far from possible ignition sources when using solvents to clean machinery. Many solvents are toxic when inhaled or ingested. Use care when disposing of waste rags and towels to be sure they DO NOT create fire or environmental hazards.</p>
--	---

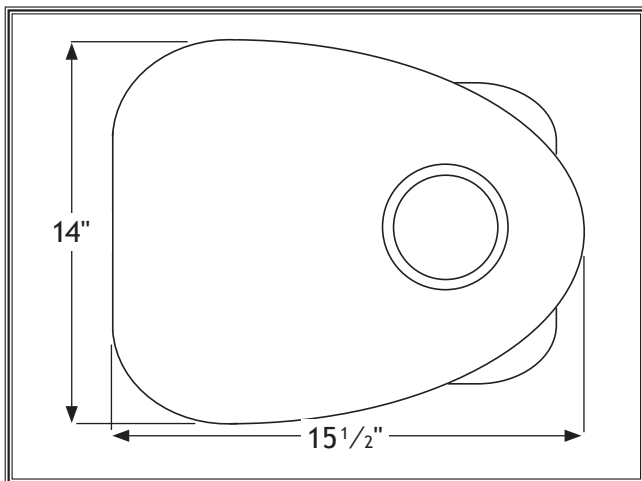

Figure 4. Working clearances.

Bench Mounting

The base of this machine has mounting holes that allow it to be fastened to a workbench or other mounting surface to prevent it from moving during operation and causing accidental injury or damage.

The strongest mounting option is a "Through Mount" (see **Figure 5**) where holes are drilled all the way through the workbench—and hex bolts, washers, and hex nuts are used to secure the machine in place.

Another option is a "Direct Mount" (see **Figure 6**) where the machine is secured directly to the workbench with lag screws and washers.

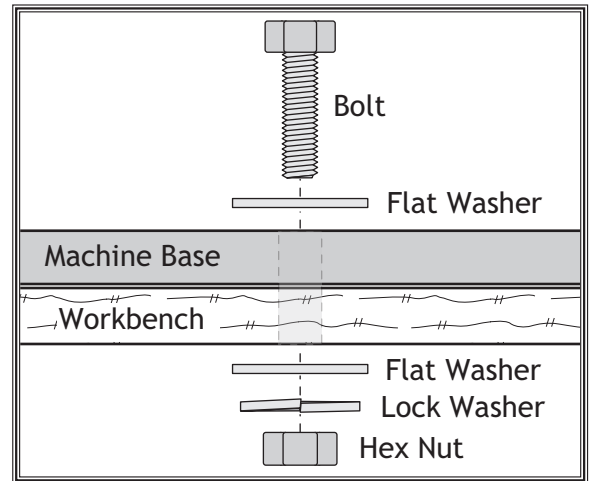

Figure 5. Example of a through mount.

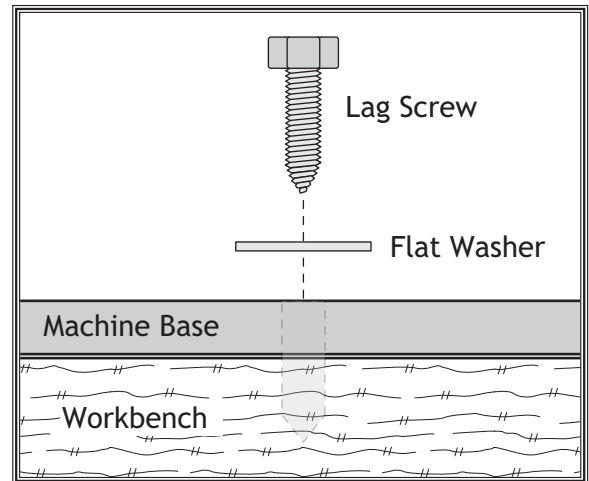

Figure 6. Example of a direct mount.

SETUP

Assembly

Place the spindle hex nut, table inserts, sanding drums and sleeves, and spindle washers in the appropriate sized accessory slots beneath the table.

Note: A sanding drum does not need to be installed until after the test run.

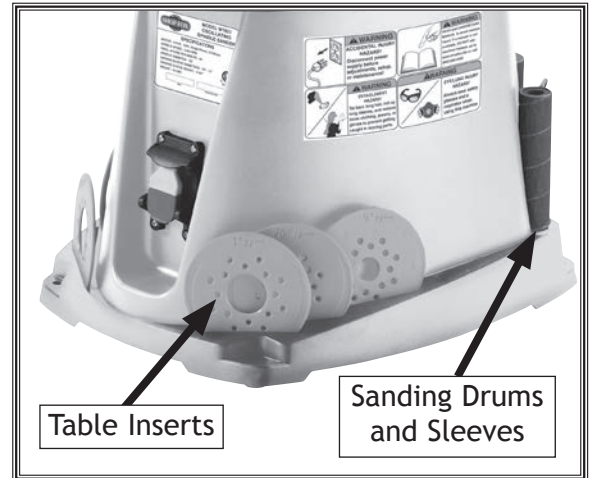

Figure 7. Table inserts, drums, and sleeves placed on sander base.

Dust Collection

Recommended CFM at Dust Port: 100 CFM

Do not confuse this CFM recommendation with the rating of the dust collector. To determine the CFM at the dust port, you must take into account many variables, including the CFM rating of the dust collector, the length of hose between the dust collector and the machine, the amount of branches or Y's, and the amount of other open lines throughout the system. Explaining this calculation is beyond the scope of this manual. If you are unsure of your system, consult an expert or purchase a good dust collection "how-to" book.

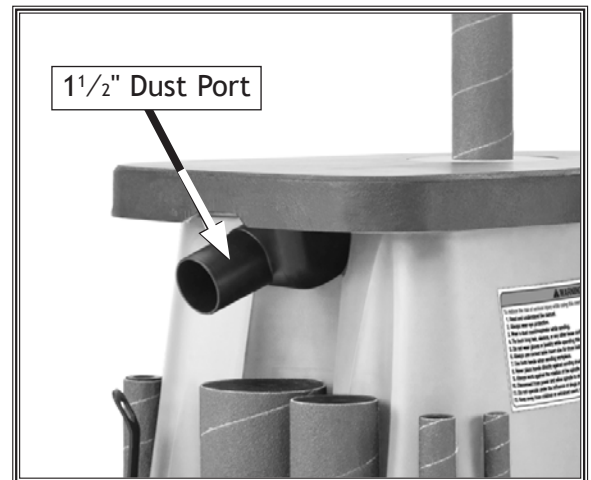

Figure 8. Dust port location.

CAUTION

DO NOT operate this machine without an adequate dust collection system. This machine creates substantial amounts of wood dust while operating. Failure to use a dust collection system can result in short and long-term respiratory illness.

SETUP

Test Run

Once the assembly is complete, test run your machine to make sure it runs properly and is ready to operate.

Note: You do not need to install a drum to perform the test run.

The test run consists of verifying the following: 1) The motor powers up and runs correctly, and 2) the safety disabling mechanism on the switch works correctly.

If, during the test run, you cannot easily locate the source of an unusual noise or vibration, stop using the machine immediately, then review **Troubleshooting on Page 22**. If you still cannot remedy a problem, contact our Tech Support at (360) 734-3482 for assistance.

To test run the machine:

1. Make sure you understand the safety instructions at the beginning of the manual, and verify that the machine is setup properly.
2. Ensure all tools and objects used during setup are cleared away from the machine.
3. Connect the machine to the power source.
4. Verify that the machine is operating correctly by turning the machine **ON**.
 - When operating correctly, the machine runs smoothly with little or no vibration or rubbing noises.
 - Investigate and correct strange or unusual noises or vibrations before operating the machine further. Always disconnect the machine from power when investigating or correcting potential problems.
5. Turn the machine **OFF**.
6. Remove the switch disabling key (see **Figure 9**).
7. Try to start the machine with the paddle switch.
 - If the machine does not start, the switch disabling feature is working as designed.
 - If the machine starts, immediately stop the machine. The switch disabling feature is not working correctly. Call Tech Support for help.



SETUP

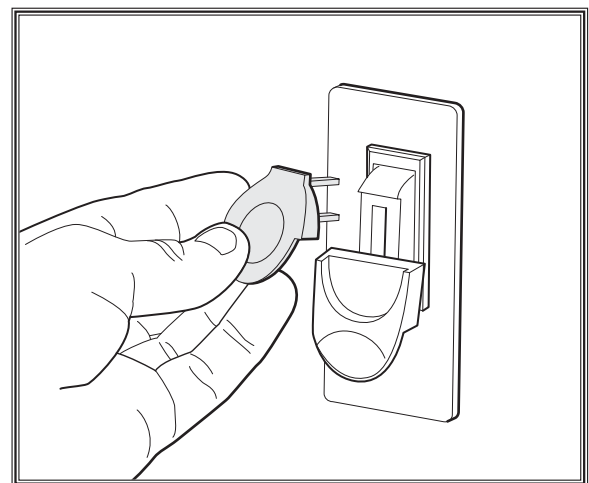

Figure 9. Removing switch key from paddle switch.

OPERATIONS

General

This machine will perform many types of operations that are beyond the scope of this manual. Many of these operations can be dangerous or deadly if performed incorrectly.

The instructions in this section are written with the understanding that the operator has the necessary knowledge and skills to operate this machine. **If at any time you are experiencing difficulties performing any operation, stop using the machine!**

If you are an inexperienced operator, we strongly recommend that you read books or trade articles, or seek training from an experienced *Sander* operator before performing any unfamiliar operations. **Above all, your safety should come first!**

⚠ WARNING

READ and understand this entire instruction manual before using this machine. Serious personal injury may occur if safety and operational information is not understood and followed. DO NOT risk your safety by not reading!

Disabling Switch

The switch can be disabled by removing the key, as shown in the following figure. Disabling the switch in this manner can prevent unauthorized operation of the machine, which is important if it is not kept inside an access-restricted building or in a location where children may be present.

⚠ WARNING

Disabling the switch only restricts its function. It is not a substitute for disconnecting the machine from power when adjusting or servicing.

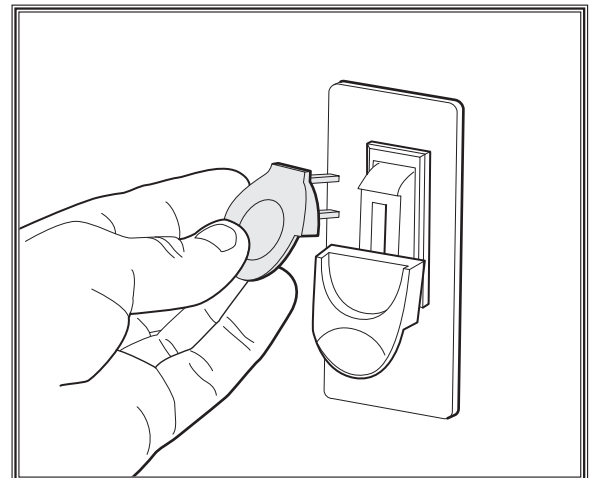

Figure 10. Removing switch key from paddle switch.

OPERATIONS

Sanding Drum/Sleeve Installation

To ensure the workpiece is supported during sanding operations, use the table insert that matches the corresponding drum and sleeve (see **Figure 11**). It is important to keep the gap between the table insert and drum as small as possible to reduce the risk of a pinch hazard.

To install or replace a sanding drum/sleeve:

1. DISCONNECT SANDER FROM POWER.
2. While holding the sanding drum and sleeve, use the arbor wrench to loosen and remove the spindle hex nut.
3. Remove the spindle washer, sanding sleeve, sanding drum, table insert and base washer (see **Figure 12**).
4. Clean the table opening for the table insert and any other spindle areas as necessary. There should be no sawdust on the ledge of the table opening where the table insert is placed or the table insert will not sit flush with the table.
5. Use the table in **Figure 11** to select the required size of components for the sanding drum/sleeve size you have chosen.
6. Insert the base washer, then install the desired sanding drum on the spindle shaft, followed by the corresponding sanding sleeve on the drum, as shown in **Figure 12**.
7. Secure the sanding drum with the appropriate spindle washer and the spindle hex nut. Tighten until the rubber sanding drum is snug against the sanding sleeve.

Sanding

To sand a workpiece:

1. Turn the spindle sander **ON** and allow it to reach full speed.
2. Using both hands to maintain control of the workpiece, guide the workpiece against the rotation of the spindle, as shown in **Figure 13**. **DO NOT** force the workpiece against the sanding sleeve. Allow the machine to do the work.

Sanding Sleeves	Sanding Drums	Table Inserts	Spindle Washers
1/2"	N/A	1/2"	5/8"
3/4"	3/4"	3/4"	3/4"
1"	1"	1"	7/8"
1 1/2"	1 1/2"	1 1/2"	1 3/4"
2"	2"	2"	1 3/4"
3"	3"	3"	1 3/4"

Figure 11. Sanding components table.

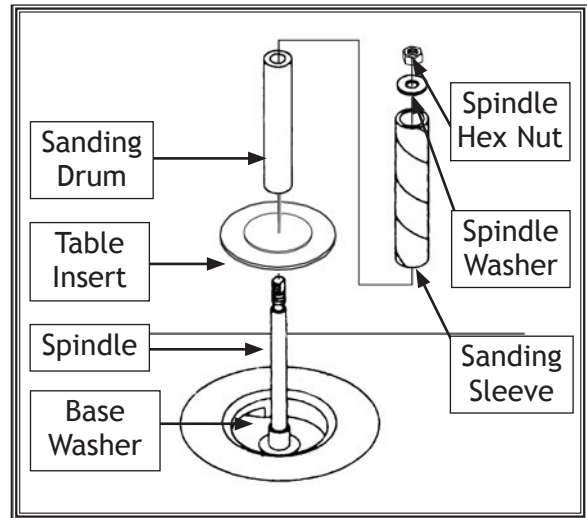

Figure 12. Removal/installation order of sanding drum components and table inserts.

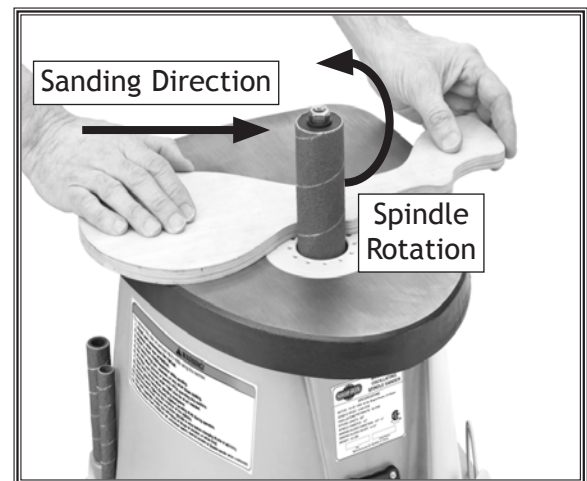

Figure 13. Sanding workpiece.

OPERATIONS

ACCESSORIES

Sander Accessories

The following Sander accessories may be available through your local Woodstock International Inc. Dealer. If you do not have a dealer in your area, these products are also available through online dealers. Please call or e-mail Woodstock International Inc. Customer Service to get a current listing of dealers at: 1-800-840-8420 or at sales@woodstockint.com.

These **PRO-STIK®** crepe-rubber Belt Cleaners quickly remove gum and grit from belts, sleeves and discs without damage. Extend the life of your belts, sleeves or discs with this innovative natural cleaner.

- W1306—Large (1½" x 1½" x 8½")
- W1307—Small (2" x 2" x 12")
- W1304—1¾" x 4¼"
- W1305—1¾" x 8½"

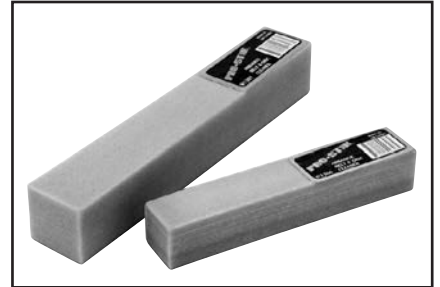

The **Shop Fox D3640 Tool Table Plus** was designed in response to customer requests for a slightly wider and taller table to accommodate small planers, wood lathes, sanders and a variety of other bench-top machines.



The **Shop Fox Hard Sanding Sleeves** are made of rigid aluminum oxide and are perfect for use with popular oscillating spindle sanders and sanding drum kits. Available in diameters from ¼" to 4" and coming in 60, 80, 100, 120 and 150 grit.



Item	Size	Grit	Pack
D3365	2" x 4½"	60 Grit	3-Pack
D3366	2" x 4½"	80 Grit	3-Pack
D3367	2" x 4½"	100 Grit	3-Pack
D3368	2" x 4½"	120 Grit	3-Pack
D3369	2" x 4½"	150 Grit	3-Pack
D3370	3" x 4 ½"	60 Grit	3-Pack
D3371	3" x 4 ½"	80 Grit	3-Pack
D3372	3" x 4 ½"	100 Grit	3-Pack
D3373	3" x 4 ½"	120 Grit	3-Pack
D3374	3" x 4 ½"	150 Grit	3-Pack

MAINTENANCE

Schedule

For optimum performance from your machine, follow this maintenance schedule and refer to any specific instructions given in this section.

Before Each Use

- Inspect the sanding drums and sleeves for wear or damage.
- Check for worn or damaged wires.
- Check for any other unsafe condition that could hamper operation of this machine or cause potential injury.

After Each Use

- Turn the sander *OFF*.
- Clean up any sawdust or particle residue from the machine.
- Protect table.

Monthly Maintenance

- Clean/vacuum dust buildup from inside the sander body and off of the motor.

Cleaning

To clean your machine, vacuum excess wood chips and sawdust, and wipe off any remaining dust with a dry cloth. Sawdust and other particles can also work their way under the table insert, so this area also needs to be cleaned. Sanding sleeves can be cleaned with the PRO-STIK® cleaners on [Page 18](#).

To clean the table:

1. DISCONNECT SANDER FROM POWER.
2. Remove sanding drum and table insert as described in the [Sanding Drum/Sleeve Installation](#) instructions on [Page 17](#).
3. Wipe or vacuum out any dust or particles that have accumulated beneath the table insert on the table opening, shown in [Figure 14](#).
4. Re-install table insert and sanding drum.
5. To protect the table from rust, coat the table surface with a quality metal protectant.

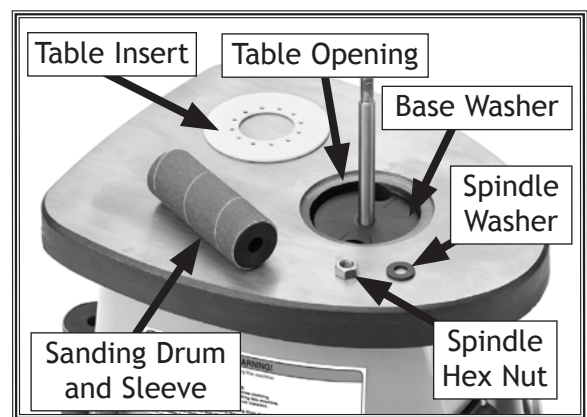
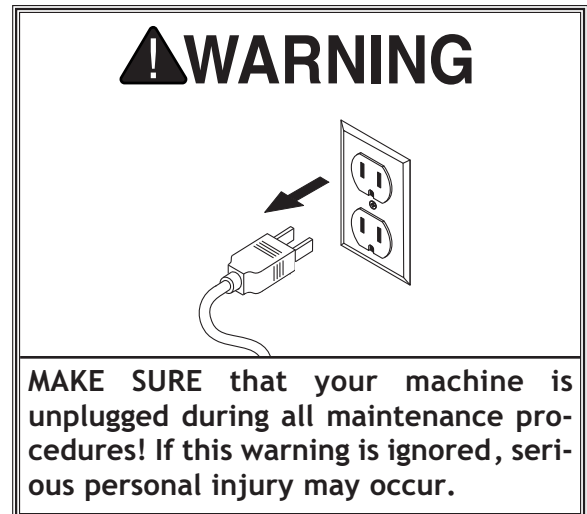

Figure 14. Table insert area.

SERVICE

General

This section covers the most common service adjustments or procedures that may need to be made during the life of your machine.

If you require additional machine service not included in this section, please contact Woodstock International Technical Support at (360) 734-3482 or send e-mail to: tech-support@shopfox.biz.

Changing Motor Brushes

This sander has a permanent magnet motor that uses carbon brushes for operation. These brushes normally wear out over time and eventually need to be replaced.

Symptoms indicating that the brushes have worn beyond their usable life may include a loss of power, inconsistent operation of the motor (motor cuts in and out inexplicably), or an inability of the motor to start.

If you are having trouble with the performance of the motor, first refer to **Troubleshooting on Page 22** to determine if the motor brushes must be replaced.

A pair of new brushes can be purchased from your Shop Fox dealer by requesting part #W1831033A. The replacement procedure can usually be done in about 15 minutes. When replacing the brushes, we recommend replacing them one at a time so you can keep track of which wire connects to each brush.

Please note: The brush assemblies have locating prongs (see **Figure 15**) that insert into the motor to hold the brush housing in position. Take care when removing the brush assemblies to pull them out first instead of just up.

⚠ WARNING

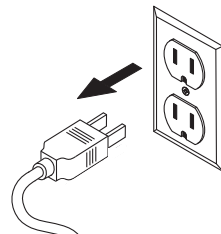

MAKE SURE that your machine is unplugged during all service procedures! If this warning is ignored, serious personal injury may occur.

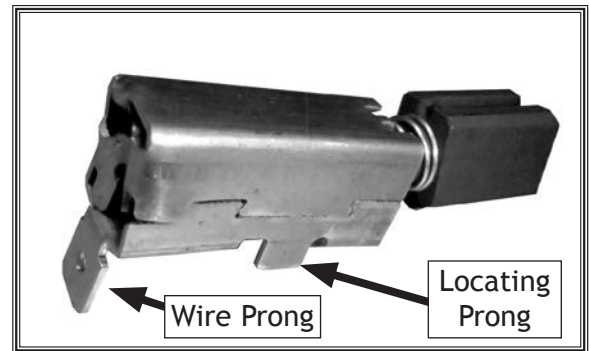

Figure 15. Motor brush assembly.

Tools Required: Qty
Screwdriver Phillips #2..... 1

To change motor brushes:

1. DISCONNECT SANDER FROM POWER.
2. Turn machine on its side, and remove the screws securing the base plate, then remove the base plate to allow access to the motor.
3. Disconnect the wire attached to the motor brush assembly.
4. Loosen the screws that secure the clamp plate over the brush assemblies (see **Figure 16**) but do not completely remove the plate.
5. Gently pull the brush assembly straight toward you and then upward to remove it.
6. Install new motor brush assembly.
7. Tighten the clamp plate back in place.
8. Repeat these steps to change the second motor brush assembly.
9. Reconnect the wire to the motor brush.
10. Replace the base plate.

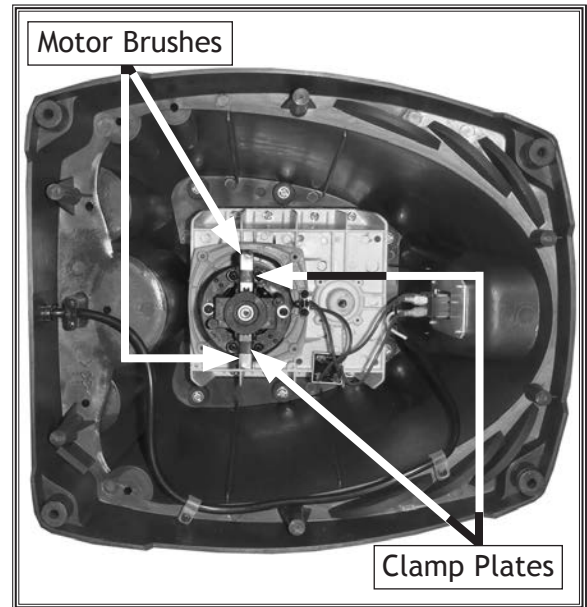
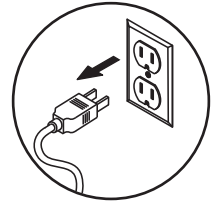

Figure 16. Motor brush location on motor.

Troubleshooting



This section covers the most common problems and corrections with this type of machine. **WARNING! DO NOT** make any adjustments until power is disconnected and moving parts have come to a complete stop!

PROBLEM	POSSIBLE CAUSE	CORRECTIVE ACTION
Motor will not start.	<ol style="list-style-type: none"> 1. Switch disabling key removed. 2. Loose connections at motor or switch. 3. Motor brushes worn. 	<ol style="list-style-type: none"> 1. Insert key to enable switch. 2. Inspect all motor connections for loose or open connections. 3. Replace motor brushes as a set.
Motor will not start; fuses or circuit breakers blow.	<ol style="list-style-type: none"> 1. Short circuit in line cord or plug. 2. Loose connections at motor switch. 3. Switch, bridge rectifier or motor at fault. 	<ol style="list-style-type: none"> 1. Inspect cord and plug for damaged insulation or shorted wires. 2. Inspect all motor connections for loose or shorted terminals or worn insulation. 3. Replace the component at fault.
Motor stalls (resulting in blown fuses or tripped circuit).	<ol style="list-style-type: none"> 1. Motor overloaded. 	<ol style="list-style-type: none"> 1. Reduce feeding pressure.
Machine slows when operating.	<ol style="list-style-type: none"> 1. Workpiece pressure is too great. 	<ol style="list-style-type: none"> 1. Secure machine to workbench.
Deep sanding grooves or scars in workpiece.	<ol style="list-style-type: none"> 1. Sanding sleeve too coarse for the desired finish. 2. Workpiece sanded across the grain. 3. Too much feeding pressure against workpiece. 	<ol style="list-style-type: none"> 1. Use a finer grit sanding sleeve. 2. Sand with the grain. 3. Reduce pressure on workpiece while sanding.
Grains rub off the sanding sleeve.	<ol style="list-style-type: none"> 1. Sanding sleeve has been stored in an incorrect environment. 2. Sanding sleeve has been folded or smashed. 	<ol style="list-style-type: none"> 1. Store sanding sleeve away from extremely dry or hot temperatures. 2. Store sanding sleeves separately and not folded or flat.
Sanding surfaces clog quickly or burn.	<ol style="list-style-type: none"> 1. Too much pressure against sleeve. 2. Sanding softwood or wood with a high sap content. 	<ol style="list-style-type: none"> 1. Reduce pressure on workpiece while sanding. 2. Either use different wood or plan on cleaning/ replacing sleeves frequently.
Burn marks on workpiece.	<ol style="list-style-type: none"> 1. Using too fine of sanding grit. 2. Using too much pressure. 3. Work held still for too long. 	<ol style="list-style-type: none"> 1. Use a coarser grit sanding sleeve. 2. Reduce pressure on workpiece while sanding. 3. Do not keep workpiece in one place for too long.

Wiring Diagram

⚠️ WARNING

Incorrectly wiring or grounding this machine can cause electrocution, fire, or machine damage. To reduce this risk, only an electrician or qualified service personnel should do any required electrical work on this machine.

⚠️ WARNING

Touching electrified parts will result in personal injury including but not limited to severe burns, electrocution, or death. Disconnect the power from the machine before servicing electrical components!

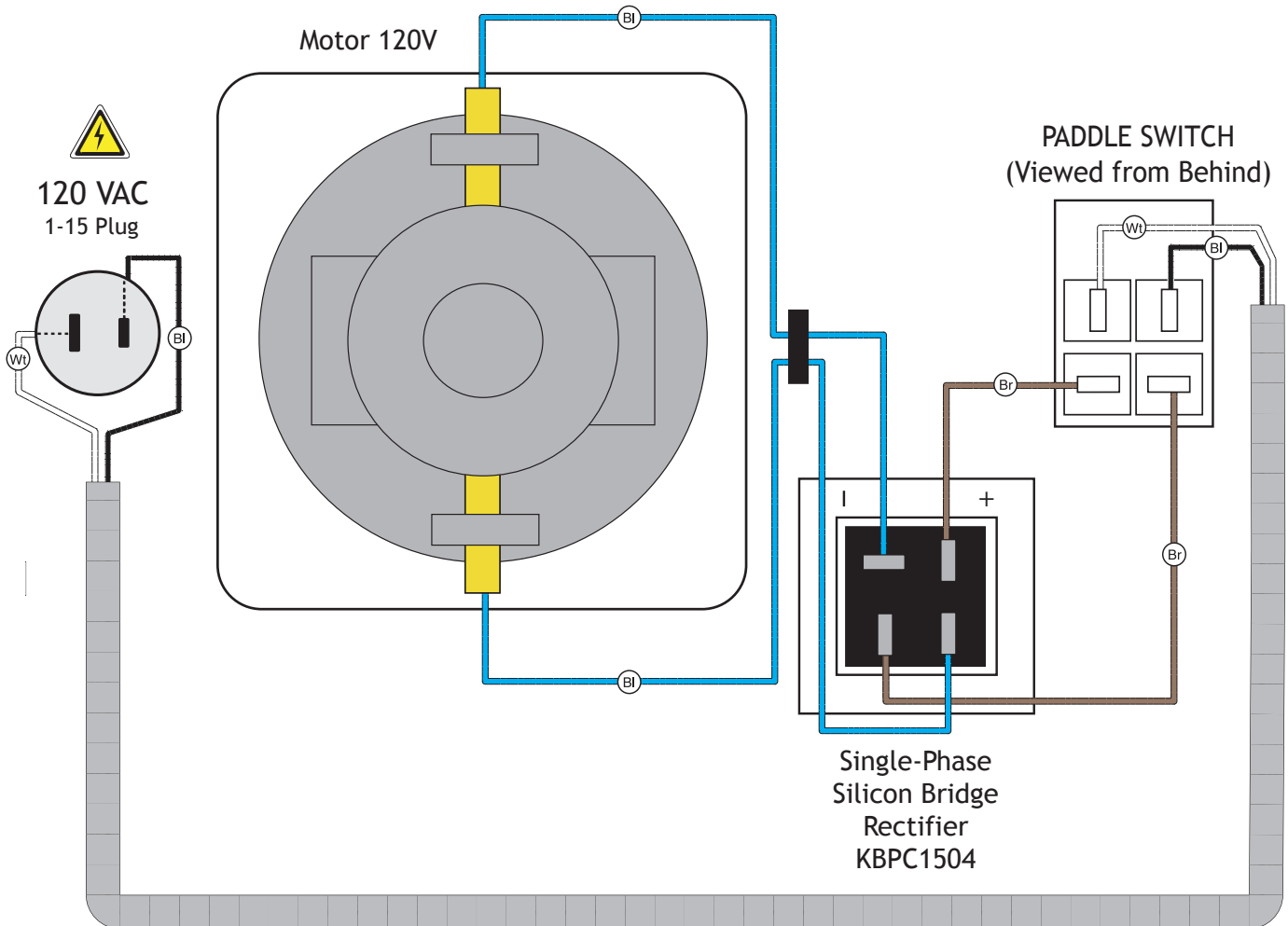

SERVICE

PARTS

Main Breakdown

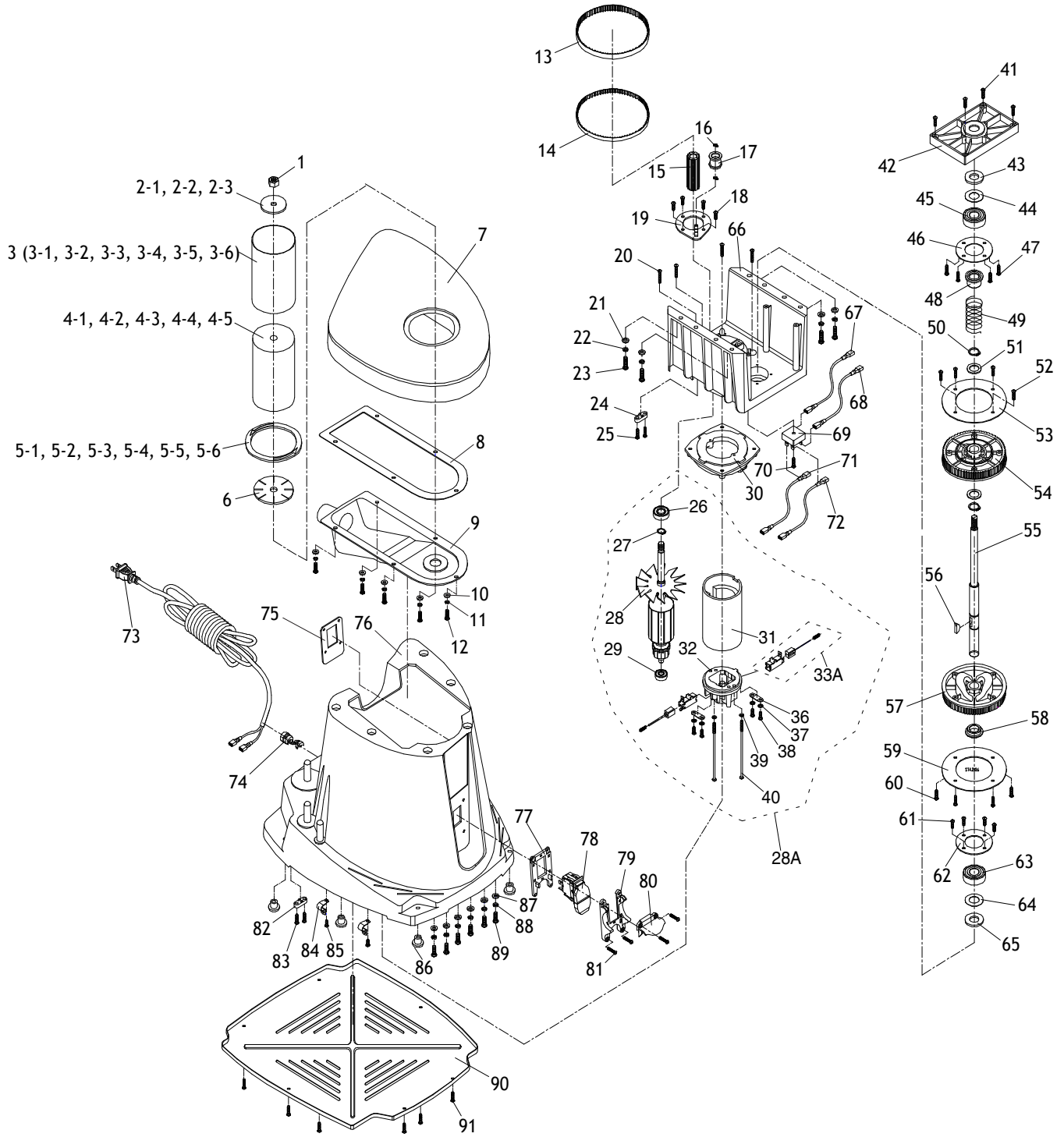

Main Parts List

REF	PART #	DESCRIPTION
1	X1831001	SPINDLE HEX NUT M10-1.5
2-1	X1831002-1	SPINDLE WASHER 5/8" OD
2-2	X1831002-2	SPINDLE WASHER 7/8" OD
2-3	X1831002-3	SPINDLE WASHER 1-3/4" OD
3	X1831003	SANDING SLEEVE SET OF 6
3-1	X1831003-1	SANDING SLEEVE 1/2"
3-2	X1831003-2	SANDING SLEEVE 3/4"
3-3	X1831003-3	SANDING SLEEVE 1"
3-4	X1831003-4	SANDING SLEEVE 1-1/2"
3-5	X1831003-5	SANDING SLEEVE 2"
3-6	X1831003-6	SANDING SLEEVE 3"
4-1	X1831004-1	SANDING DRUM 3/4"
4-2	X1831004-2	SANDING DRUM 1"
4-3	X1831004-3	SANDING DRUM 1-1/2"
4-4	X1831004-4	SANDING DRUM 2"
4-5	X1831004-5	SANDING DRUM 3"
5-1	X1831005-1	TABLE INSERT 1/2" ID
5-2	X1831005-2	TABLE INSERT 3/4" ID
5-3	X1831005-3	TABLE INSERT 1" ID
5-4	X1831005-4	TABLE INSERT 1-1/2" ID
5-5	X1831005-5	TABLE INSERT 2" ID
5-6	X1831005-6	TABLE INSERT 3" ID
6	X1831006	BASE WASHER 2-3/4" OD
7	X1831007	CAST IRON TABLE
8	X1831008	GASKET
9	X1831009	DUST COVER
10	XPW02M	FLAT WASHER 5MM
11	XPLW01M	LOCK WASHER 5MM
12	XPS08M	PHLP HD SCR M5-.8 X 12
13	X1831013	TIMING BELT 3/8" X 160XL
14	X1831014	TIMING BELT 1/4" X 160XL
15	X1831015	DRIVE PULLEY
16	X1831016	TENSION ROLLER WASHER
17	X1831017	TENSION ROLLER ASSEMBLY
18	XPHTEK31M	TAP SCREW M4 X 14
19	X1831019	ORIENTATION PLATE ASSEMBLY
20	XPHTEK8M	TAP SCREW M4 X 20
21	XPW03M	FLAT WASHER 6MM
22	XPLW03M	LOCK WASHER 6MM
23	XPS11M	PHLP HD SCR M6-1 X 16
24	X1831024	CORD CLAMP
25	XPHTEK6M	TAP SCREW M4 X 16
26	XP6001ZZ	BALL BEARING 6001ZZ
27	XPR47M	EXT RETAINING RING 13MM
28A	X1831028A	PERMANENT MAGNET MOTOR ASSEMBLY
28	X1831028	ARMATURE ASSEMBLY
29	XP608ZZ	BALL BEARING 608ZZ
30	X1831030	CONNECTION PLATE
31	X1831031	FIELD ASSEMBLY
32	X1831032	REAR COVER
33A	X1831033A	MOTOR BRUSH ASSEMBLY 1 PAIR
36	X1831036	CORD CLAMP
37	XPTLW11M	INT TOOTH WASHER 4MM
38	XPHTEK31M	TAP SCREW M4 X 14

REF	PART #	DESCRIPTION
39	XPW05M	FLAT WASHER 4MM
40	X1831040	TAP SCREW M4 X 110
41	XPHTEK8M	TAP SCREW M4 X 20
42	X1831042	BEARING COVER
43	X1831043	FELT WASHER
44	X1831044	RUBBER WASHER
45	XP6203ZZ	BALL BEARING 6203ZZ
46	X1831046	UPPER BEARING SUPPORT
47	XPHTEK6M	TAP SCREW M4 X 16
48	X1831048	BEARING SLEEVE
49	X1831049	COMPRESSION SPRING
50	XPR18M	EXT RETAINING RING 17MM
51	X1831051	SPINDLE WASHER
52	XPHTEK31M	TAP SCREW M4 X 14
53	X1831053	DRIVE GEAR PLATE
54	X1831054	DRIVE GEAR
55	X1831055	SPINDLE
56	X1831056	WOODRUFF KEY
57	X1831057	DIFFERENTIAL GEAR
58	X1831058	BEARING SLEEVE
59	X1831059	DIFFERENTIAL GEAR PLATE
60	XPHTEK31M	TAP SCREW M4 X 14
61	XPHTEK31M	TAP SCREW M4 X 14
62	X1831062	LOWER BEARING SUPPORT
63	XP6203ZZ	BALL BEARING 6203ZZ
64	X1831064	RUBBER WASHER
65	X1831065	FELT WASHER
66	X1831066	GEAR SUPPORT
67	X1831067	WIRE ASSEMBLY 18G 1W 9"
68	X1831067	WIRE ASSEMBLY 18G 1W 9"
69	X1831069	RECTIFIER
70	XPHTEK8M	TAP SCREW M4 X 20
71	X1831071	WIRE ASSEMBLY 18G 1W 6"
72	X1831071	WIRE ASSEMBLY 18G 1W 6"
73	X1831073	POWER CORD 18G 2W 6" 1-15
74	X1831074	STRAIN RELIEF 6N-4
75	X1831075	REAR SWITCH PLATE
76	X1831076	HOUSING BASE
77	X1831077	FRONT SWITCH PLATE
78	X1831078	SAFETY PADDLE SWITCH
79	X1831079	SWITCH BRACKET
80	X1831080	SWITCH BRACKET COVER
81	XPS56M	PHLP HD SCR M4-.7 X 16
82	X1831082	POWER CORD HOLDER
83	XPHTEK6M	TAP SCREW M4 X 16
84	X1831084	CABLE HOLDER 18G
85	XPHTEK15M	TAP SCREW M4 X 10
86	X1831086	RUBBER FOOT
87	XPW03M	FLAT WASHER 6MM
88	XPLW03M	LOCK WASHER 6MM
89	XPS11M	PHLP HD SCR M6-1 X 16
90	X1831090	BOTTOM PLATE
91	XPHTEK31M	TAP SCREW M4 X 14

Label Placement

⚠️ WARNING

Safety labels warn about machine hazards and how to prevent serious personal injury. The owner of this machine **MUST** maintain the original location and readability of all labels on this machine. If any label is removed or becomes unreadable, **REPLACE** that label before allowing machine to be operated again. Contact us at (360) 734-3482 or www.shopfoxtools.com to order new labels.

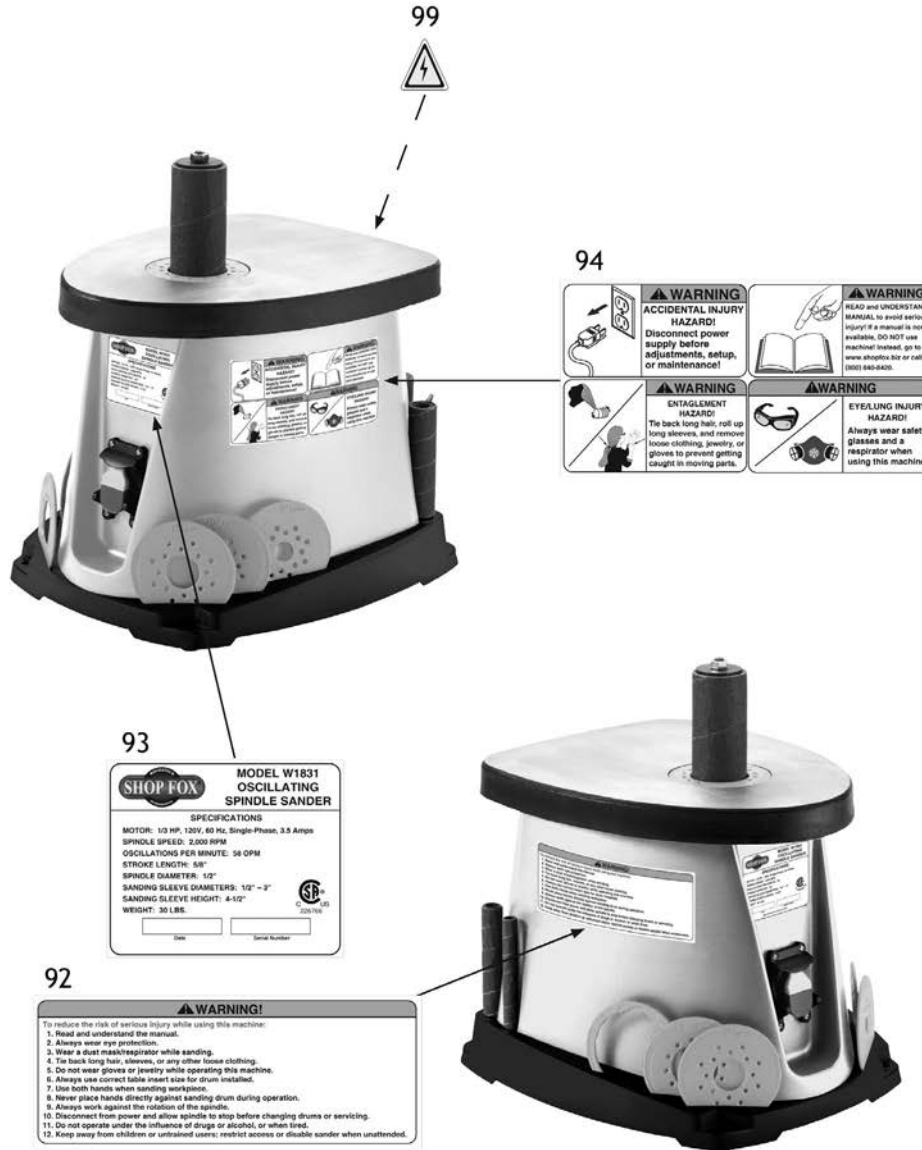

REF	PART #	DESCRIPTION
92	X1831092	WARNING LABEL
93	X1831093	MACHINE ID LABEL

REF	PART #	DESCRIPTION
94	X1831094	MACHINE HAZARDS LABEL
99	XLABEL-04B	ELECTRICITY LABEL



Warranty Registration

Name _____
 Street _____
 City _____ State _____ Zip _____
 Phone # _____ Email _____ Invoice # _____
 Model # _____ Serial # _____ Dealer Name _____ Purchase Date _____

The following information is given on a voluntary basis. It will be used for marketing purposes to help us develop better products and services. Of course, all information is strictly confidential.

- How did you learn about us?
 Advertisement Friend Local Store
 Mail Order Catalog Website Other:
- How long have you been a woodworker/metalworker?
 0-2 Years 2-8 Years 8-20 Years 20+ Years
- How many of your machines or tools are Shop Fox?
 0-2 3-5 6-9 10+
- Do you think your machine represents a good value? Yes No
- Would you recommend Shop Fox products to a friend? Yes No
- What is your age group?
 20-29 30-39 40-49
 50-59 60-69 70+
- What is your annual household income?
 \$20,000-\$29,000 \$30,000-\$39,000 \$40,000-\$49,000
 \$50,000-\$59,000 \$60,000-\$69,000 \$70,000+
- Which of the following magazines do you subscribe to?

<input type="checkbox"/> Cabinet Maker	<input type="checkbox"/> Popular Mechanics	<input type="checkbox"/> Today's Homeowner
<input type="checkbox"/> Family Handyman	<input type="checkbox"/> Popular Science	<input type="checkbox"/> Wood
<input type="checkbox"/> Hand Loader	<input type="checkbox"/> Popular Woodworking	<input type="checkbox"/> Wooden Boat
<input type="checkbox"/> Handy	<input type="checkbox"/> Practical Homeowner	<input type="checkbox"/> Woodshop News
<input type="checkbox"/> Home Shop Machinist	<input type="checkbox"/> Precision Shooter	<input type="checkbox"/> Woodsmith
<input type="checkbox"/> Journal of Light Cont.	<input type="checkbox"/> Projects in Metal	<input type="checkbox"/> Woodwork
<input type="checkbox"/> Live Steam	<input type="checkbox"/> RC Modeler	<input type="checkbox"/> Woodworker West
<input type="checkbox"/> Model Airplane News	<input type="checkbox"/> Rifle	<input type="checkbox"/> Woodworker's Journal
<input type="checkbox"/> Modeltec	<input type="checkbox"/> Shop Notes	<input type="checkbox"/> Other:
<input type="checkbox"/> Old House Journal	<input type="checkbox"/> Shotgun News	

9. Comments: _____

CUT ALONG DOTTED LINE

FOLD ALONG DOTTED LINE

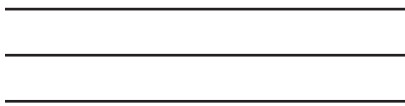

Place
Stamp
Here



WOODSTOCK INTERNATIONAL INC.
P.O. BOX 2309
BELLINGHAM, WA 98227-2309



FOLD ALONG DOTTED LINE

TAPE ALONG EDGES--PLEASE DO NOT STAPLE

WARRANTY

Woodstock International, Inc. warrants all Shop Fox machinery to be free of defects from workmanship and materials for a period of two years from the date of original purchase by the original owner. This warranty does not apply to defects due directly or indirectly to misuse, abuse, negligence or accidents, lack of maintenance, or reimbursement of third party expenses incurred.

Woodstock International, Inc. will repair or replace, at its expense and at its option, the Shop Fox machine or machine part, which in normal use has proven to be defective, provided that the original owner returns the product prepaid to a Shop Fox factory service center with proof of their purchase of the product within two years, and provides Woodstock International, Inc. reasonable opportunity to verify the alleged defect through inspection. If it is determined there is no defect, or that the defect resulted from causes not within the scope of Woodstock International Inc.'s warranty, then the original owner must bear the cost of storing and returning the product.

This is Woodstock International, Inc.'s sole written warranty and any and all warranties that may be implied by law, including any merchantability or fitness, for any particular purpose, are hereby limited to the duration of this written warranty. We do not warrant that Shop Fox machinery complies with the provisions of any law or acts. In no event shall Woodstock International, Inc.'s liability under this warranty exceed the purchase price paid for the product, and any legal actions brought against Woodstock International, Inc. shall be tried in the State of Washington, County of Whatcom. We shall in no event be liable for death, injuries to persons or property or for incidental, contingent, special or consequential damages arising from the use of our products.

Every effort has been made to ensure that all Shop Fox machinery meets high quality and durability standards. We reserve the right to change specifications at any time because of our commitment to continuously improve the quality of our products.



High Quality Machines and Tools

Woodstock International, Inc. carries thousands of products designed to meet the needs of today's woodworkers and metalworkers.

Ask your dealer about these fine products:

BROSENA
PRECISION STOP BLOCK

JOINTER PAL[®]

Rotacator[®]

THE REBEL[®]

DURASTICK[®]

Gutmann[®]

BOARD BUDDIES[®]



Junglee[®]

PLANER PAL[®]

PARROT VISE[®]

SLICKPLANE[®]

PRO-STIK[®]
ABRASIVE BELT & DISC CLEANER

ACCU-SHARP[®]

Aluma-Classic[®]



STEELEX[®]
FINE TOOLS

STEELEX[®]
PLUS



WHOLESALE ONLY

WOODSTOCK INTERNATIONAL, INC.

Phone: (360) 734-3482 • Fax: (360) 671-3053 • Toll Free Fax: (800) 647-8801

P.O.Box 2309 • Bellingham, WA 98227

SHOPFOX.BIZ